

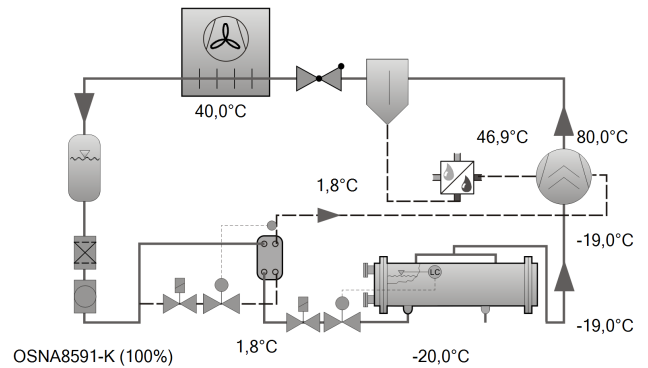

Selection: Open Screw Compressors OS

Input Values

Compressor model	OSNA8591-K
Refrigerant	R717
Reference temperature	Dew point temp.
Evaporating SST	-20,00 °C
Condensing SDT	40,0 °C
Liq. subc. (in condenser)	0 K
Auto. subcooling	Auto
Suct. gas superheat	1,00 K
Operating mode	Economiser
Speed	2900 /min
Useful superheat	100%
Additional cooling	Automatic
Max. discharge gas temp.	80,0 °C
Cooling capacity	100 %



Result

Compressor	OSNA8591-K
Cooling capacity	100%
Cooling capacity	256 kW
Cooling capacity *	253 kW
Evaporator capacity	256 kW
Shaft power	97,2 kW
Condenser capacity	295 kW
COP/EER	2,64
COP/EER *	2,61
Mass flow LP	749 kg/h
Mass flow HP	871 kg/h
Operating mode	Economiser
Liquid temp. (sc)	1,80 °C
Mass flow ECO	122,2 kg/h
sub cooler load	37,3 kW
sat. ECO Temp.	1,80 °C
ECO pressure	4,60 bar(a)
Oil volume flow	3,63 m³/h
Cooling method	External
Oil injection temp. comp.	46,9 °C
Oil cooler load	58,1 kW
Recommended driving motor	132,0 kW
Discharge gas temp. with cooling	80,0 °C
Discharge gas temp. w/o cooling	--

Tentative Data.

Additional cooling/ limitations (see Limits)!

Starting point for motor selection see T. Data/ Notes

Selection only valid for flooded systems

*According to EN12900 (5K suction gas superheat, open flash)

Application Limits ECO OSNA8591

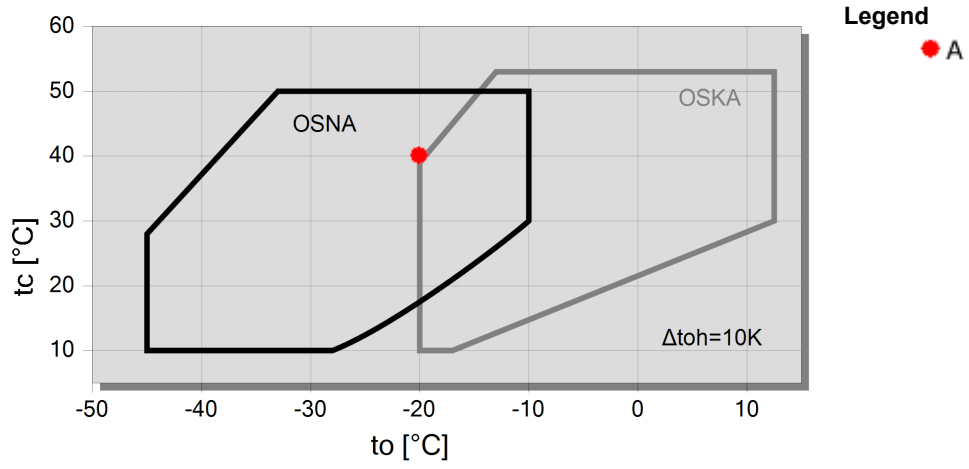



Technical Data: OSNA8591-K

Dimensions and Connections

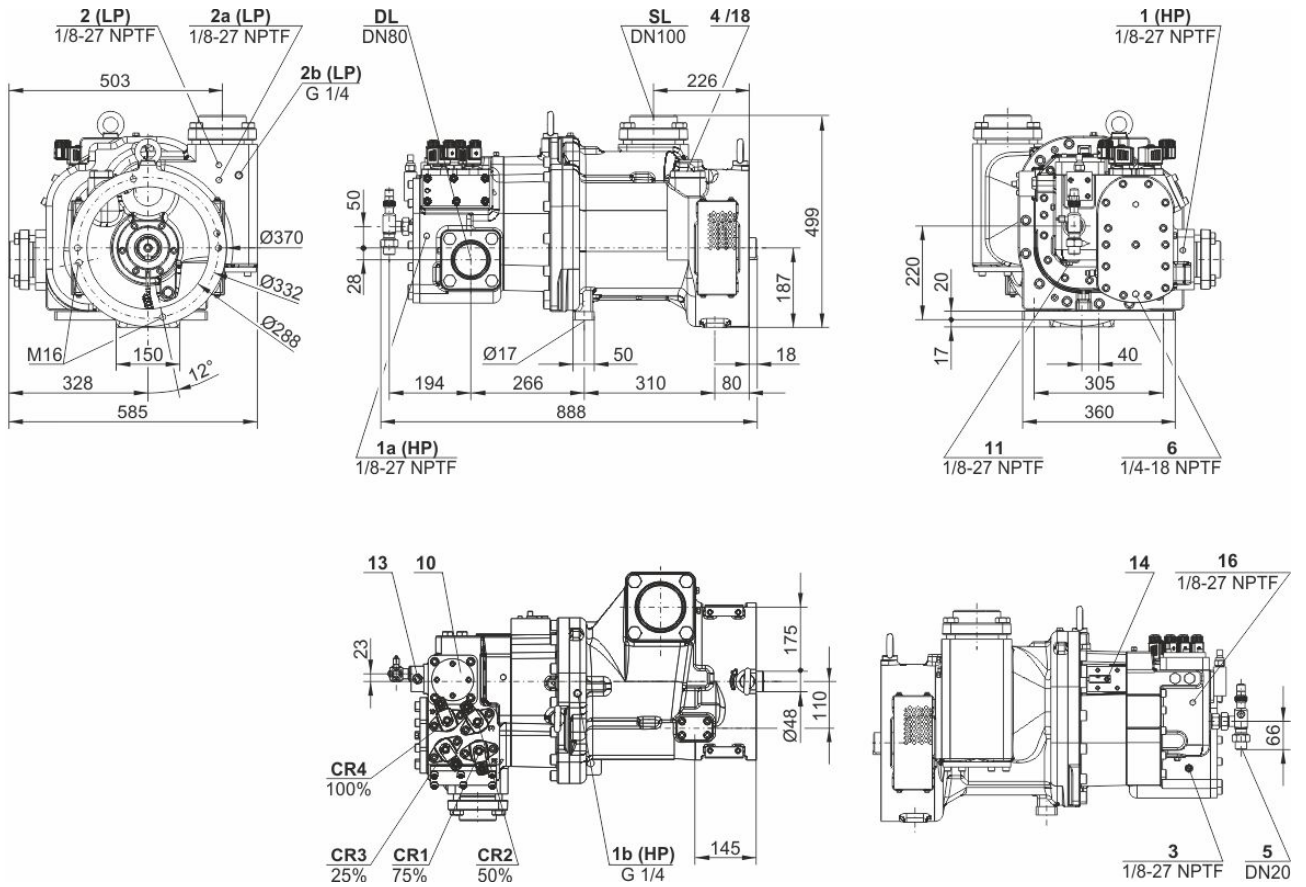



Technical Data

Technical Data

Displacement (2900rpm 50 Hz)	535 m ³ /h
Displacement (3500rpm 60 Hz)	646 m ³ /h
Allowed speed range	1450 .. 4000 min ⁻¹
Sense of rotation (compressor)	rechts / clockwise
Weight	360 kg
Max. pressure (LP/HP)	19 / 28 bar
Connection suction line	DN 100
Connection suction line (NH3)	DN 100
Connection discharge line	76 mm - 3 1/8"
Connection discharge line (NH3)	DN 80
Adapter for ECO (NH3)	DN 30 (Option)
Oil type NH3	Reniso KC68 , SHC 226E

Extent of delivery (standard)

Pressure relief valve	Standard
Check valve	Standard
Oil flow control	Standard
Oil stop valve	Standard
Built in oil filter	Standard
discharge gas temperature monitoring	2xSE-B3
Discharge gas temperature sensor	Standard
Start unloading	Standard
Capacity control	100-75-50% or 100-50% (Standard)
Protective charge	Standard

Available options

Suction shut-off valve	Option
Discharge shut-off valve	Option
ECO connection with shut-off valve	Option
Coupling housing	Option
CM-SW-01	Option



Open Screw Compressors OS

OSK = Application for air-conditioning and medium temperature cooling.

OSN = Application for low temperature cooling.

OSH = Application for air-conditioning and heat pumps.

Notes regarding application limits (see "T.Data - Limits")

* Ranges are valid for standart operation and at full-load conditions.

* With high pressure conditions, part-laod operation is partly limited (see application limits in applications manual SH-500 / SH-510).

* With Economizer operation the maximum admissible evaporation temperature is shifted by 10 K downward (otherwise there is a danger of excessive compression and overlaod of the motor because of a higher mass flow). At pull-down conditions from higher evaporation temperatures, the ECO injection must remain closed until the evaporation temperature is below the maximum admissible value and a stable operation is achieved (e.g. control of the ECO solenoid valve by means of a low pressure cut-out). The use of the ECO-System with higher evaporation temperatures requires individual consultation with Bitzer.

OS53..OS74

* Capacity control with ECO operation at the same time is limited to one single regulating step (CR 75 %). At CR 50 % the ECO injection should be closed.

* Combined operation (ECO + CR 50 %) is possible under certain conditions, control and system design, however, require individual consultation with Bitzer.

Motor Selection

The required driving motor is selected for starting conditions at direct start as well as at star-delta-start with start unloading (50 % capcaity regulation). The starting conditions refer to the following defined operation points resp. to the maximum application limit of the compressor. Should the evaporation- or the condensing temperature of the plant be higher at the start, an individual motor selection is necessary.

	Evaporation temperature for motor selection			
	HH	H	M	L
R134a	+20 °C	+12,5 °C	-5 °C	
R404A / R507A		+7,5 °C	-5 °C	-15 °C
R22		+12,5 °C	-5 °C	-10 °C
R407C		+12,5 °C	-5 °C	
NH□	+25 °C	+12,5 °C	-5 °C	-10 °C

The stated motor data refer to IEC motors at which the pull-up torque should not fall below 90 % of the max. torque. In addition the following starting torque (referring to direct start) must be reached:

* open screw compressors 120 %

Should the motor not fulfil these criteria, an individual selection is also necessary.

Lubricants and additional cooling for NH3 applications

	Type	Viscosity	Discharge gas (°C)	Oil injection (°C)
Reniso KM32	MO	32	ca. 60 .. max. 100	max. 50
Reniso KS46	MO	46	ca. 60 .. max. 80 (100 [1])	max. 60
Reniso KC68	MO	68	ca. 60 .. max. 80 (100 [1])	max. 60
Reflo 68A	MO (HT)	58	ca. 60 .. max. 80 (100 [1])	max. 60
SHC226E	PAO	68	ca. 60 .. max. 80 (100 [1])	max. 60

[1] 100°C only after consultation with BITZER

Further information on the selection of lubricants can be found in the Application Manuals SH-500 and SH-510.